

PROP INSTALLATION NOTES:

CONFIRM THAT PROP TAPER CONTACTS SHAFT TAPER WITHOUT INTERFERENCE FROM KEY, TIGHTEN PROP NUT (SHORTER OF TWO), SEAT PROPELLER BY STRIKING PROP HUB WITH DEAD BLOW TYPE Mallet, RETIGHTEN PROP NUT, INSTALL SECOND NUT TIGHT AGAINST FIRST, INSTALL COTTER PIN, INSTALL ZINC ANODE 4" AHEAD OF STRUT BEARING

INSTALL AND MAINTAIN SHAFT SEAL IN ACCORDANCE WITH MANUFACTURER'S INSTRUCTIONS

ALL COMPONENTS ARE INSTALLED BELOW WATER LINE !
BEFORE LAUNCH, TIGHTEN ALL HOSE CLAMPS,

DRIVE FLANGES ARE SUBJECT TO FULL FOREWARD AND REVERSE THRUST !

CLAMP BOLTS AND SET SCREW ARE ALL THAT SECURES SHAFT FROM PULLING OUT IN REVERSE

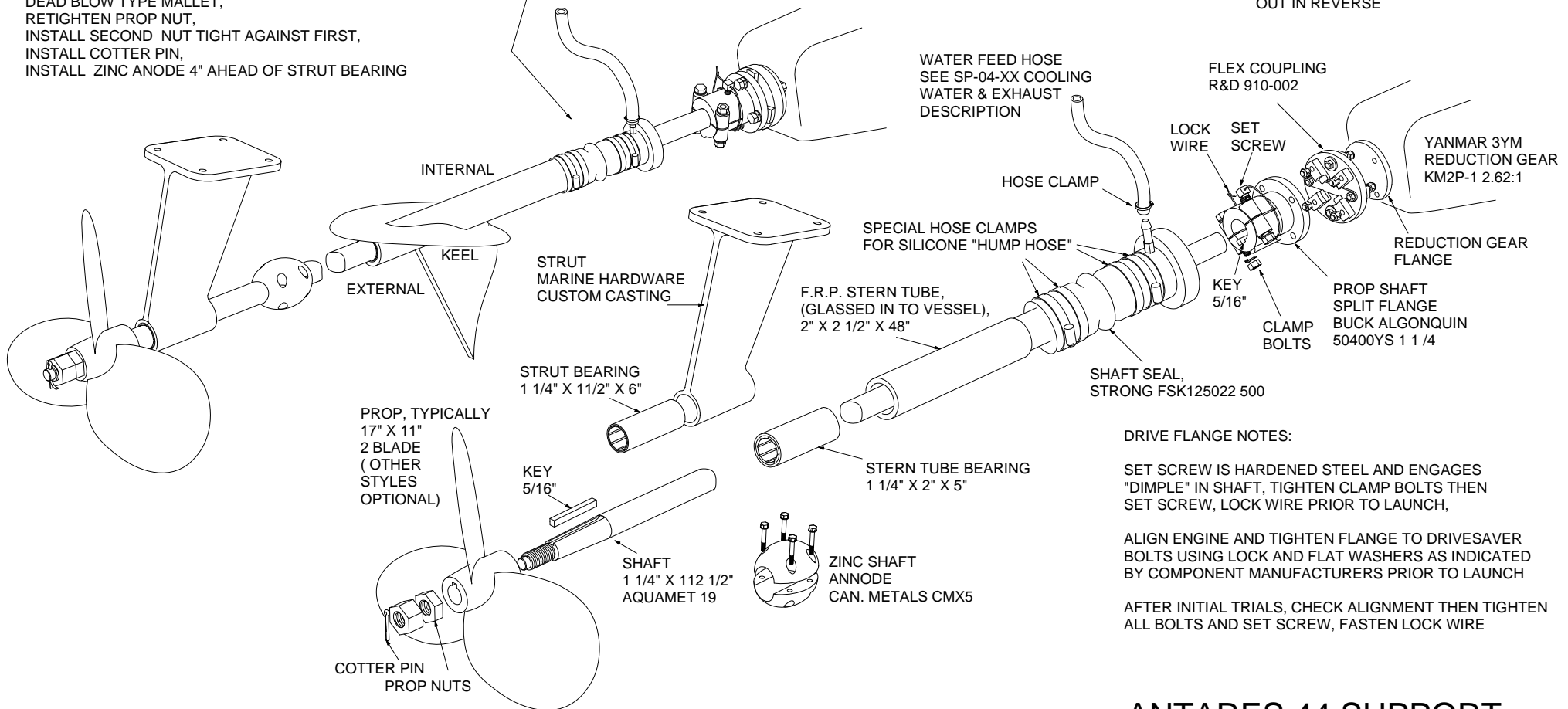

SHAFT BEARINGS ARE "CUTLESS" TYPE AND ARE LINED WITH FLUTED RUBBER. CLEARANCE IS LARGE AND MAY BE UP TO .075" BEFORE RENEWAL. FISHING LINE WRAPS WILL DAMAGE RUBBER INSERT, ROPE WRAPS MAY DAMAGE BEARING AND TUBE ASSEMBLY

INSPECT ALL INTERNAL COMPONENTS PRIOR TO DEPARTURE AND AT INTERVALS WHILE RUNNING. SHAFT SEAL, ZINC ANODES AND DRIVE COMPONENTS ARE REGULAR MAINTENANCE ITEMS

DRIVE FLANGE NOTES:

SET SCREW IS HARDENED STEEL AND ENGAGES "DIMPLE" IN SHAFT, TIGHTEN CLAMP BOLTS THEN SET SCREW, LOCK WIRE PRIOR TO LAUNCH,

ALIGN ENGINE AND TIGHTEN FLANGE TO DRIVESAVER BOLTS USING LOCK AND FLAT WASHERS AS INDICATED BY COMPONENT MANUFACTURERS PRIOR TO LAUNCH

AFTER INITIAL TRIALS, CHECK ALIGNMENT THEN TIGHTEN ALL BOLTS AND SET SCREW, FASTEN LOCK WIRE

ANTARES 44 SUPPORT SHAFT LINE COMPONENTS ME-04-10

ISSUED APRIL 14, 2008
FIRST VESSEL USED 4427

TC

DRAWING FOR YANMAR 3YM30